

# FM TONE GENERATOR SYSTEM TX216/TX816

## SERVICE MANUAL

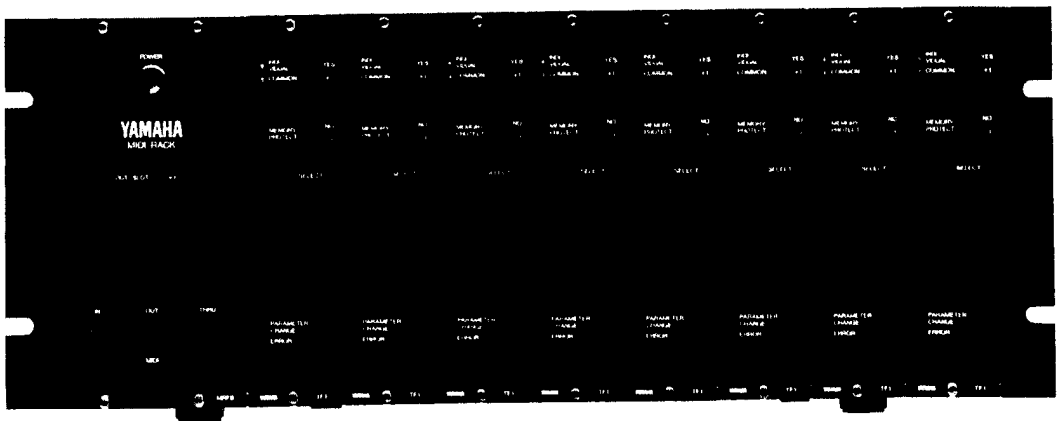

TX816

### ● CONTENTS

IMPORTANT NOTICE .....	1	TEST PROGRAM. ....	9
DIMENSIONS .....	1	TX816 MIDI DATA FORMAT .....	10 - 23
SPECIFICATIONS .....	2	CIRCUIT BOARDS (Parts Side). ....	24 - 26
ERROR DISPLAYS .....	2	BLOCK DIAGRAM .....	27
PANEL LAYOUT .....	3	PARTS LIST .....	28-34
TX816 BRIEF DESCRIPTION .....	4 - 6	SCHEMATIC DIAGRAM. ....	35/36
TX816 FLOW CHART .....	7/8		

006619

SINCE 1887



# YAMAHA

NIPPON GAKKI CO, LTD. HAMAMATSU. JAPAN

| .75k -304 Printed in Japan 85.2

# IMPORTANT NOTICE

## IMPORTANT NOTICE

This manual has been provided for the use of authorized Yamaha Retailers and their service personnel. It has been assumed that basic service procedures inherent to the industry, and more specifically Yamaha Products, are already known and understood by the users, and have therefore not been restated.

**WARNING:** Failure to follow appropriate service and safety procedures when servicing this product may result in personal injury, destruction of expensive components and failure of the product to perform as specified. For these reasons, we advise all Yamaha product owners that all service required should be performed by an authorized Yamaha Retailer or the appointed service representative.

**IMPORTANT:** The presentation or sale of this manual to any individual or firm does not constitute authorization, certification, recognition of any applicable technical capabilities, or establish a principleagent relationship of any form.

The data provided is believed to be accurate and applicable to the unit/s indicated on the cover. The research, engineering, and service departments of Yamaha are continually striving to improve Yamaha products. Modifications are, therefore, inevitable and changes in specification are subject to change without notice or obligation to retrofit. Should any discrepancy appear to exist, please contact the distributor's Service Division.

**WARNING:** Static discharges can destroy expensive components. Discharge any static electricity your body may have accumulated by grounding yourself to the ground buss in the unit (heavy gauge black wires connect to this buss).

**IMPORTANT:** Turn the unit OFF during disassembly and parts replacement. Recheck all work before you apply power to the unit.

## DIMENSIONS

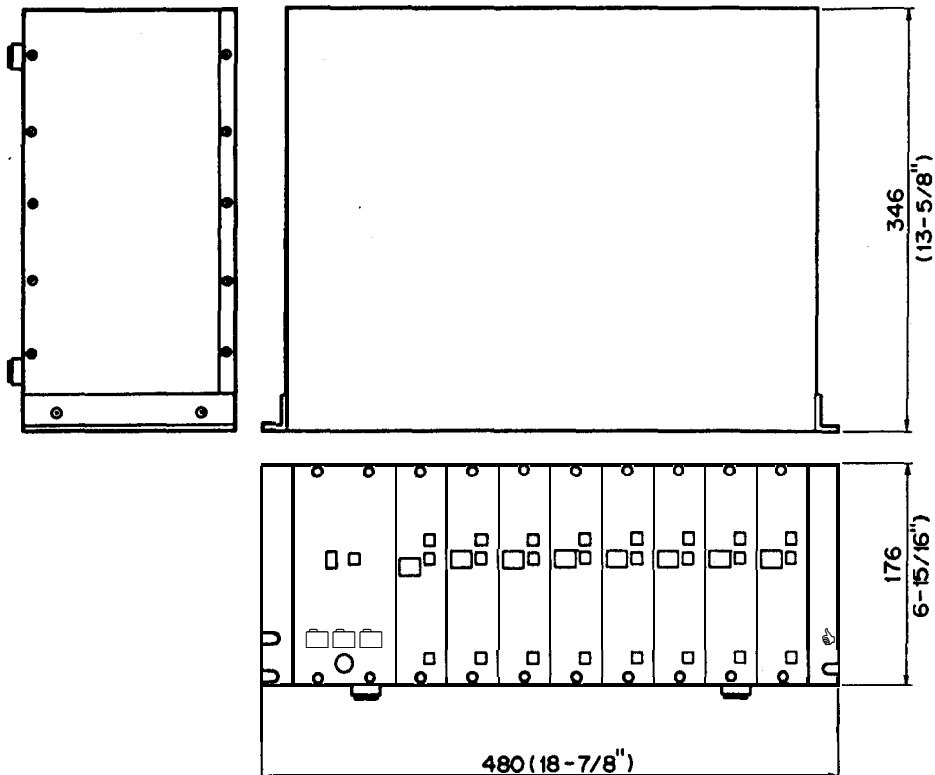

Unit : mm (Inch)

## Specifications

	TX216	TX816
<b>CONFIGURATION</b>	MIDI RACK FRAME TFI FM Tone Generator x 2	MIDI RACK FRAME TFI FM Tone Generatorx8
<b>POWER REQUIREMENTS</b>		
<b>U.S./Canadian models</b>	120 V (60Hz)	120 V (160 Hz)
<b>(General model)</b>	100- 120/220-240 V (50/60 Hz)	100- 120/220-240 V (50/60 Hz)
<b>POWER CONSUMPTION</b>	2.2 W	70 w
<b>DIMENSIONS</b>	480x 176x346 mm	480x176x346 mm
<b>(WxHxD)</b>	(18-7/8"x6-15/16"x13-5/8")	(18-7/8"x6-15/16,x13-5/8")
<b>WEIGHT</b>	10 kg (22 lbs.)	12 kg (26 lbs. 6 oz.1
<b>STANDARD ACCESSORIES</b>	MIDI cable 11.5 m (5 ft.)x2) MIDI cable (5 m (16.4 ft.11 Socket wrench	MIDI cable (1.5 m (5 ft.)x8) MIDI cable (5m (16.4 ft.11 Socket wrench

### MIDI RACK FRAME

<b>TERMINALS</b>	MIDI IN, MIDI OUT, MIDI THRU (5-pin DIN)
<b>CONTROLS</b>	Power ON/OFF, MIDI Out Slot select
<b>MASTER CLOCK RATES</b>	9.4265 MHz
<b>DIMENSIONS</b>	486x 176x346 mm
<b>(WxHxD)</b>	(19-1/8"x6-15/16"x13-5/8")
<b>WEIGHT</b>	8 kg (17 lbs. 10 oz.1

### TFI

<b>SOUND SOURCE</b>	FM Tone Generator (6 Operators)
<b>SIMULTANEOUS NOTES OUTPUT</b>	Polyphonic-16 (first note priority) Monophonic-1 (last note priority)
<b>INTERNAL MEMORY</b>	32 program (32 voice + 32 function)
<b>PANEL CONTROLS</b>	Individual/Common or YES/+ 1 Memory Protect ON/OFF or No / - 1 Mode Select
<b>LEDS</b>	Individual; Common; Memory Protect; Parameter Change; Error
<b>NUMERIC LED DISPLAY</b>	Program number, numeric data, etc.
<b>TERMINALS</b>	MIDI IN, MIDI THRU (5-pin DIN) Line Out (XLB-3-32 type)
<b>OUTPUT LEVEL</b>	- 10 dBm, 600 ohms
<b>DIMENSIONS</b>	480x176x346 mm
<b>(WxHxD)</b>	(18-7/8"x6-15/16"x13-5/8")
<b>WEIGHT</b>	600 g (1 lbs. 5 oz.)
<b>STANDARD ACCESSORIES</b>	MIDI Cable (1.5 m (5 ft.11 Socket wrench

All specifications are subject to change without notice.

### ERROR DISPLAYS

A number of error displays are built into each TFI to let you know if any internal problems are occurring. The red Error LED will light, and a number will appear in the LED Display to inform you of the type of problem. You can cancel the error display by pressing any of the three keys on the front of the module. The following chart lists the ten types of errors, and how to deal with them.

LED DISPLAY	ERROR	REMEDY
1	Data Receive Error	Indicates that data has not been properly received. Adjust the data at the source and transmit data again.
2	Receive Buffer Full	
3	Bulk Data Check Sum Error	
4	Low Battery Level	Replace Battery
5	ROM Hardware Error	These errors are all caused by a fault in the internal circuitry of the TFI, and you will need to contact your nearest Yamaha dealer.
6	RAM1 Hardware Error	
7	RAM2 Hardware Error	
6	RAM3 Hardware Error	
9	RAM4 Hardware Error	
10	Trap Error	

## ■ PANEL LAYOUT

### ● FRONT PANEL

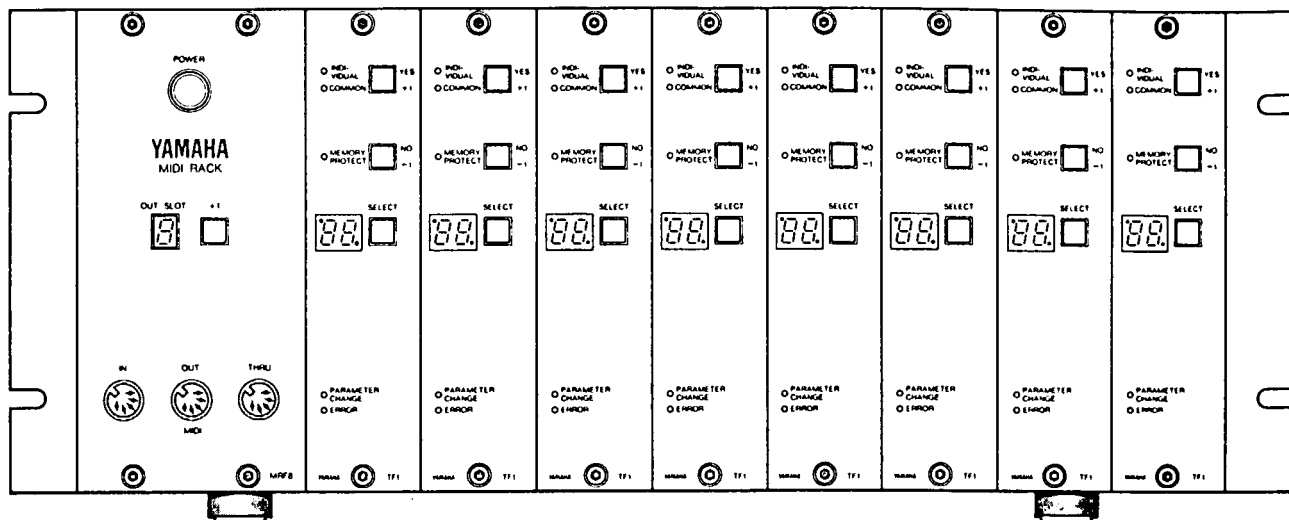

TX816

### ● REAR PANEL

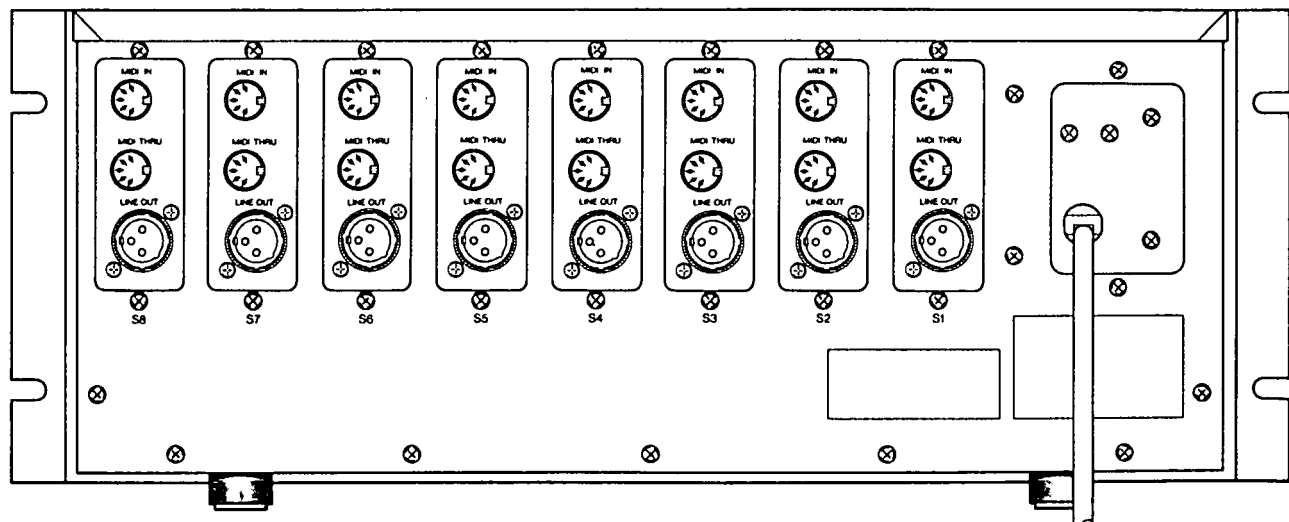

TX816

## TX816 BRIEF DESCRIPTION

### 1. TX816 Configuration

The TX816 consists of an MIDI rack main frame and eight TF1 FM tone modules. The TF1 is similar to the DX7, excluding the keyboard. The TF1 rear panel is equipped with the MIDI IN and THRU jacks and an XLR balanced output connector. The MIDI rack main frame is equipped with a power supply unit, MIDI IN, OUT, and THRU jacks, and MIDI out slot selector. When the TF1 "INDIVIDUAL" LED is on, the TF1 receives an MIDI message through the TF1 rear panel MIDI IN. If the "COMMON" LED is on, the TF1 receives messages through the front panel MIDI IN. The MIDI OUT transmits a TF1 MIDI message with a number which is displayed on the OUT SLOT LED. The power supply unit is very similar to the one used in the DX1.

### 2. TF1 circuit

The TF1 MPU is HD6303X. This MPU contains Asynchronous Communications Interface Adapter (ACIA), I/O port, and RAM. The ACIA is used for MIDI message transmission/reception, and the I/O port is used for switch on/off detection and LED lighting. The FM tone generator LSIs (EGS and OPS) are the same as those used in the DX7.

#### 2.1 MPU (HD6303X)

- Vcc and Vss

Vcc represents a +5V supply voltage, and Vss represents a GND terminal.

- XTAL and EXTAL

A 4 MHz crystal resonator is connected between these two terminals. The 4 MHz clock is divided by four and becomes a 1 MHz system clock.

- MP<sub>0</sub> and MP<sub>1</sub>

These terminals are used to set the MPU operation mode, that is, MP<sub>0</sub> = "High" and MP<sub>1</sub> = "Low".

- $\overline{\text{RES}}$

This terminal is used to reset the MPU.

- $\overline{\text{STBY}}$

This terminal is used to set the MPU in a standby mode. However, this is not used in this circuit, and its fixed to "High" logic level.

- $\overline{\text{NMI}}$

This is a nonmaskable interrupt terminal. However, this is not used in this circuit, and its fixed to "High" logic level.

- Port 2

The ports P<sub>20</sub> through P<sub>27</sub> are used for the following purposes in this circuit:

P<sub>20</sub> (out): MIDI IN INDIVIDUAL/Common changeover

P<sub>21</sub> (out): "INDIVIDUAL" LED lighting

P<sub>22</sub> (out): "COMMON" LED lighting

P<sub>23</sub> (in): MIDI message receiving

P<sub>24</sub> (out): MIDI message transmission

P<sub>25</sub> (out): "MEMORY PROTECT" LED lighting

P<sub>26</sub> (out): "PARAMETER CHANGE" LED lighting

P<sub>27</sub> (out): "ERROR" LED lighting

- Port 5

Ports  $P_{50}$  through  $P_{57}$  are used for the following purposes in this circuit:

- $P_{50}$  (in): Battery voltage detection
- $P_{51}$  (in): MIDI OUT slot switching
- $P_{52}$  (in): This is a memory ready terminal to lengthen the E (enable) clock "High" period. This terminal is fixed to "High" logic level, so the E clock is a normal continuous clock.
- $P_{53}$  (in): This is a HALT terminal to stop execution of the command and open the bus. This terminal is fixed to "High", so the halt mechanism cannot be initiated.
- $P_{54}$  (in): This is fixed to "High" logic level because it is not used.
- $P_{55}$  (in): "INDIVIDUAL/COMMON" switch detection
- $P_{56}$  (in): "MEMORY PROTECT" switch detection
- $P_{57}$  (in): "SELECT" switch detection

- Port 6

The ports  $P_{60}$  through  $P_{67}$  are connected to the HA17408 Digital to Analog Converter (IC10), which outputs the data for the level attenuator and battery voltage comparator.

- Bus

$A_0$  through  $A_{15}$  represent the address bus, and  $D_0$  through  $D_7$  represent the data bus.

- BA

This is a bus available terminal will outputs "High" logic level when the MPU receives a  $\overline{\text{HALT}}$  command and the buses become available. This terminal is not used in this circuit.

- $\overline{\text{LIR}}$

This terminal indicates whether the command operation code is loaded in the data bus. This terminal is not used in this circuit.

- $\text{R}/\overline{\text{W}}$

This outputs a "High" logic level when the MPU is in the read mode, and a "Low" logic level when the MPU is in the write mode.

- $\overline{\text{WR}}$

This outputs a "Low" logic level when the MPU is in the write mode.

- $\overline{\text{RD}}$

This outputs a "Low" logic level when the MPU is in the read mode.

- E

This is an enable terminal to output the system clock.

## 2.2 System reset

When power is on, IC20 (PST518) generates a system reset signal. Pin 12 (IC20) outputs a RES signal, and Pin 10 (IC20) outputs a  $\overline{\text{RES}}$  signal. The  $\overline{\text{RES}}$  signal is sent to the EGS, the battery backup circuit and the output muting circuit.

## 2.3 MIDI IN

The MIDI IN is provided with a rear panel INDIVIDUAL MIDI jack and a front panel COMMON MIDI jack. If the MIDI IN is switched to INDIVIDUAL with the INDIVIDUAL/COMMON switch, the MPU port  $P_{21}$  will be "Low" and LED 1 will light. Simultaneously, the MPU port  $P_{20}$  will be "Low" and the MIDI message which is input to the panel MIDI IN jack will be input to the MPU port  $P_{23}$ . If the MIDI IN is switched to COMMON, port  $P_{22}$  will be "Low" and LED 2 will light. And simultaneously port  $P_{20}$  will be "High" and the MIDI message is input from the panel MIDI IN jack to port  $P_{23}$ . The received MIDI message is written in the intra-MPU ACIA receive shift register.

## 2.4 MIDI OUT

If a "Low" logic level is input to the MPU port  $P_{51}$  with the panel OUT SLOT switch, the MIDI message which is read by the intra-MPU ACIA transmit shift register is output from port  $P_{24}$  and then sent to the front panel MIDI OUT jack.

## 2.5 Digital to analog (D/A) converter

MPU Port 6, 8 bits of data is converted into an analog current by the IC10, and into an analog voltage by the IC32. This analog voltage is generally used to drive the level attenuator photocoupler, but, in the case of the UTILITY mode, it is used for comparison with battery voltage so that the backup battery voltage can be displayed. The current through the photocoupler LED will then be reduced instantly. But this poses no problems with audibility, due to slow photocoupler response speed.

## 2.6 Address decoder and address map

The IC13 (74LS138 decoder) decodes higher order 5 bits of the address, and selects ROM or I/O ICs. The address map is listed below.

0000-001F: Intra-MPU register  
 0040-00FF: Intra-MPU RAM  
 4000-47FF: RAM 1 (IC5)  
 4800-4FFF: RAM 2 (IC6)  
 5000-57FF: RAM 3 (IC7)  
 5800-5FFF: RAM 4 (IC8)  
 6000-60FF: EGS (IC2)  
 6800-6801: OPS (IC3)

77FF: Display data latch (IC11)  
 7800: Display data latch (IC12)  
 C000-FFFF: ROM (IC4)

## 2.7 Tone generator

The intra-EGS registers are selected by addresses A0 through A7, and data to produce sound is written into each register. The EGS terminals E1 through E12 send envelope data to the OPS, and the F1 through F14 terminals send frequency data to the OPS. Data which is output from the OPS terminals DA1 through DA12 is converted into an analog current by the D/A converter, and into an analog voltage by IC24. The intra-OPS output register consists of 16 bits. However, because a 12-bit D/A converter is used, the OPS outputs shifted 12-bit data in case of a lower level.

This means that lower level bits are expanded and output from the IC24. Then IC26 returns the expanded level to the original level by switching to different points of the resistive ladder. The output of IC25 does not form a complete waveform. This waveform is divided into two parts by the IC27 and IC28 to be sampled and held, and then mixed by IC30 to form a stair step waveform. This waveform then passes through the low pass filter to form a complete analog signal. This analog signal is output from the XLR connector, through the photo-coupler level attenuator and electronic balanced circuit.

## 3. MIDI rack main frame circuit

The MIDI rack main frame circuitry consists of the MIDI out slot switching circuit, clock generator and power supply.

### 3.1 Out slot switching circuit

Pressing the +1 switch (main frame front panel) increments the count data of IC1 (74LS293 counter) IC2 (74LS138 decoder) decodes this data to select one of the eight TF1 MIDI OUTs. This data is then added with "1" by IC3 (74LS283 adder), decoded and driven by IC4 (74LS247 7 segment decoder/driver), and displayed on the LED.

### 3.2 Clock generator

The CB circuit board provides with a 9.4265 MHz clock generator. The TX816 divides the 9.4265 MHz clock by two, which is then used by the EGS and OPS as  $\phi 1$  and  $\phi 2$  clock sources.

TX816 FLOW CHART

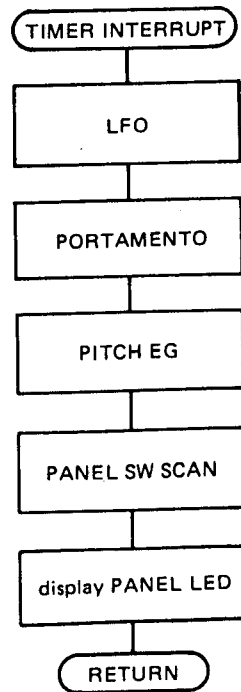
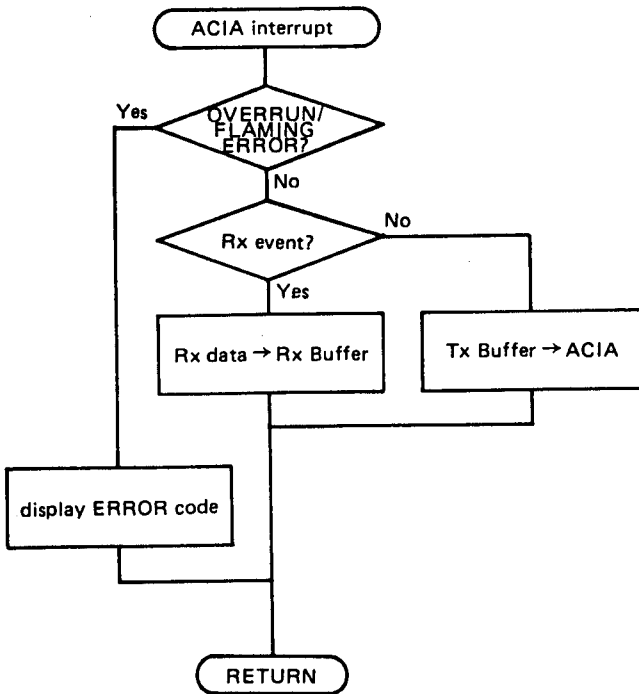
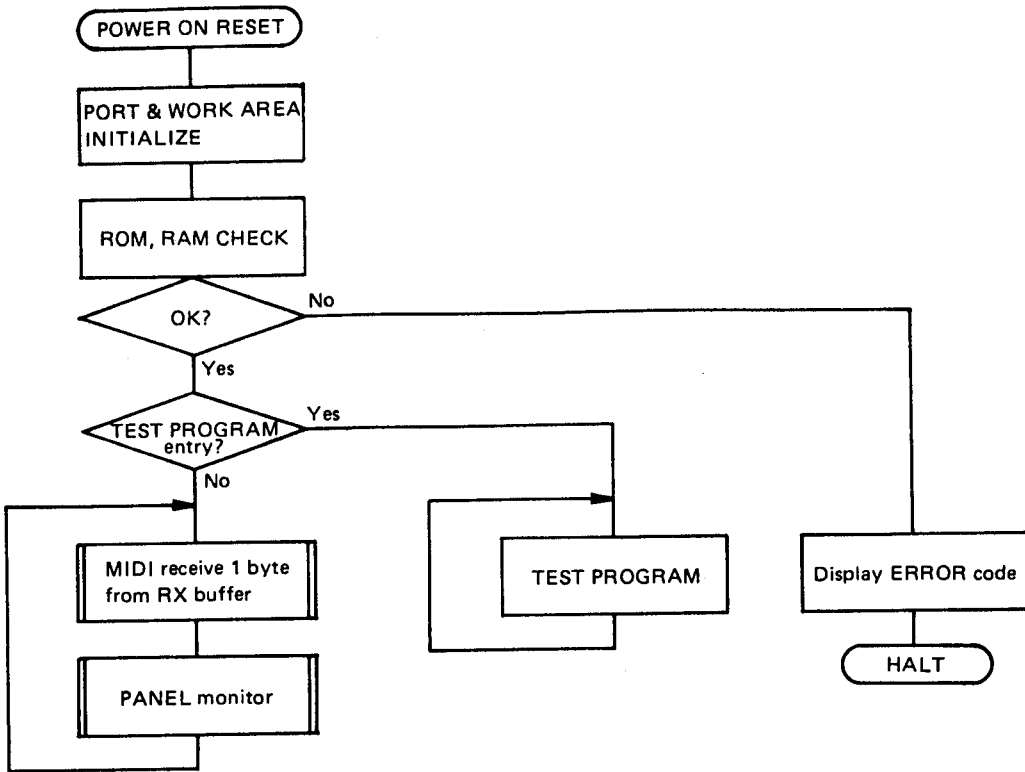



The fundamental structure of the TX816 is exactly the same as DX7.

### 1. Main routine

Data stored in the receive buffer is fetched and interpreted one byte at a time through the ACIA interrupt routine. When the message is complete, an operation which corresponds to it is executed.

MIDI receive 1 byte  
from RX buffer

The panel switch event which is detected by the timer interrupt routine changes the mode/submode and executes the job.

PANEL monitor

**Note:** An initial ROM/RAM check is performed every time the unit is turned on and it is part of the main routine.

### 2. ACIA interrupt routine

When one byte of data is received in the ACIA, the ACIA interrupt is generated, and this routine is initiated. Data is read from the ACIA, and is stored temporarily in the receive buffer.

### 3. Timer interrupt routine

- Realtime sound source control --- Calculates data such as LFO, PORTAMENTO, and PITCH EG, which vary from moment to moment, and loads it to the sound source.
  - Panel switch scan --- Scans the panel switches at a fixed interval, and performs auto-repeat processing.
  - Panel LED drive --- Performs LED lighting, time sharing display, and blinking.
- This routine is activated by the built-in timer every 2.6 sec.

## ■ TEST PROGRAM

- 1) To enter the test program, the three TF1 panel switches must be depressed and held down during power-up. The display reads **11** indicating test entry. To exit the test program, turn the Power off.

Check whether the common panel out-slot is set to 1.

- 2) Depress the YES/+ 1 switch and program will advance to the first test.  
 3) Use the YES/+ 1 switch to increment to the next test. Use the NO/-1 switch to decrement back to the previous test.  
 4) TEST 1 Output level and pitch check

When you enter this test, the display reads **11**.

During Test 1 the module (TF1) under test outputs a 440.1 Hz  $\pm$  0.1 Hz sine wave which has an output level of  $-4$  dBm  $\pm$  3 dBm.

- 5) TEST 2 LED lighting test  
 The LED indicators and numeral LED segments light successively.  
 6) TEST 3 RAM read/write test

When you enter this test, the display leads **13**.

When this test is conducted, the internal memory data is not erased.

OK: The green indicator (parameter change LED) lights.

Error: The red indicator (error LED) lights, and the error number is displayed on the LED display.

- 7) TEST 4 Auto-scaling

When you enter this test the display reads **14**.

Scaling  $C_1$  through  $C_6$  is repeated. At the same time, a voice message is output from the MIDI OUT in a pitch higher by 2 notes. Check the input/output function of the MIDI signal.

The signal is output on the MIDI OUT only when the OUT SLOT number is set to the appropriate TF1 module.

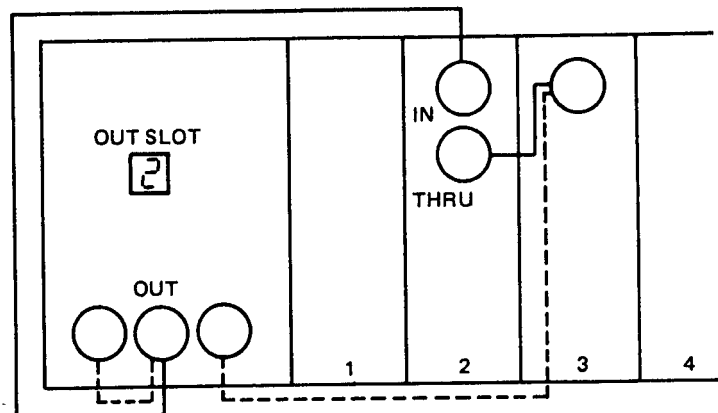

—— SLOT 2 test

----- COMMON test

The COMMON/INDIVIDUAL LED indicator of the module which receives the channel voice message flashes. COMMON/INDIVIDUAL can be switched by the SELECT button.

- 8) TEST 5 Photocoupler

When you enter this test the display reads **15**.

Check whether the level can be changed by the SELECT button as listed in the following table.

OUTPUT LEVEL ATTENUATE	L7	L6	L5	L4	L3	L2	L1	L0
Output Level (dBm)	$-4 \pm 2$	(-9)	(-14)	(-20)	(-26)	(-34)	(-41)	$-48 \pm 8$

Reference values indicated in parentheses

# TX816 MIDI DATA FORMAT

## 1. RECEPTION CONDITIONS

This chart shows the all the reception signals that can be received by the TF1. All byte numbers are expressed in hexadecimal form.

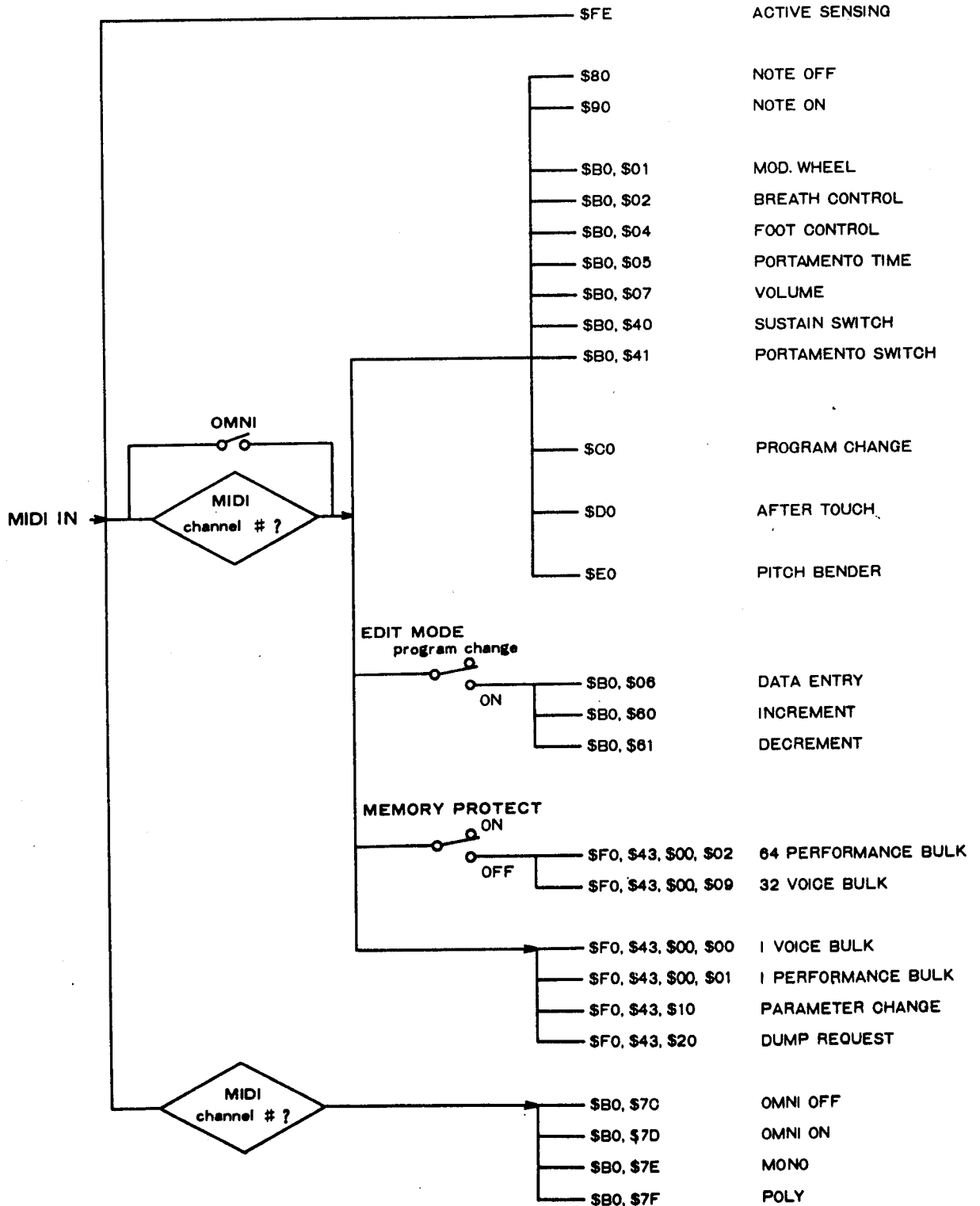

## 2. RECEPTION DATA

**NOTE:** The meaning of letters used in byte numbers will only be given once, to save repetition. For example, the letter n in byte number 1000nnnn (Key Off Status) means MIDI channel number and will mean the same when it appears in all other byte numbers.

### 2-1. Reception Channel and Omni

When the TF1 is in the Play mode, you can use the keys on the front panel to set the MIDI input channel (from 1 to 16) and switch the Omni function on or off. The Omni function permits the TF1 to receive MIDI signals on all of the 16 channels. The MIDI channel and Omni settings are memorized by the TF1, and will not change even if the power is turned off.

### 2-2. Channel Voice Message

When MIDI channel voice messages are received, either the INDIVIDUAL or the COMMON LED will rapidly turn off then on, depending on whether the signal is input at the COMMON or INDIVIDUAL MIDI IN terminal.

#### 2-2-1. Key Off

Status            1000nnnn  
                     n = MIDI channel number

Note Number      0kkkkkkk  
                     k= 0 (note C-2) to  
                     127 (note G8)

Key Velocity      0vvvvvvv  
                     v:ignore

#### 2-2-2. Key On/OFF

Status            1001nnnn

Note Number      0kkkkkkk  
                     k= 0 (note C-2) to  
                     127 (note G8)

Key Velocity      0vvvvvvv  
                     v= 0 (key off)  
                     v= 1 - 127 (key on)

### 2-2-3. Control Change

Status            1011nnnn

Control Number   0ccccccc  
                     C= 0 - 127

Control Value    0vvvvvvv  
                     v= 0 - 127

#### (a) Control Numbers For Fixed Input

C = 1      Modulation Wheel    v = 0 - 127  
 C = 2      Breath Control            v = 0 - 127  
 C = 3      Foot Control              v = 0 - 127  
 C = 5      Portamento              v = 0 - 127  
 C = 7      Volume                    v = 0 - 127  
 C = 64     Sustain Switch           v = 0, 127  
 C = 65     Portamento Switch      v = 0, 127

#### (b) Control Numbers For Front Panel Settings

These control numbers apply to the following sub-modes only: Tune Master Pitch (Play mode), Select Program Number For Edit, and Attenuate Output Level (Edit mode).

A: Tune Master Pitch  
 B: Select Program Number for Edit  
 C: Attenuate Output Level

			A	B	C
c=6	Data Entry	v=0-127	yes	yes	yes
c=96	Increment	v:neglect	yes	yes	no
c=97	Decrement	v:neglect	yes	yes	no

In the Select Program sub-mode you can alter voice or function parameters selected with Parameter Change in system exclusive..

### 2-2-4. Program Change

Status            1100nnnn

Program Number   0ppppppp  
                     Ignore the first two bits.  
                     Select 1 to 32.

2-2-5. After Touch

Status 1101nnnn  
Pressure 0vvvvvvv

⋮  
155 bytes of  
voice data sent  
d=0 to 127  
Oddddddd  
Check Sum 0eeeeeee  
EOX 11110111

2-2-6. Pitch Bend

Status 1110nnnn  
Value (LSB) 0uuuuuuu  
Value (MSB) 0vvvvvvv 8 bits resolution.  
MS 8 bits are  
recognized.

This format is for the input of the data  
of a single voice. The green Parameter  
Change LED flashes when data is received.  
The 155 bytes of voice data go into the  
Edit buffer, replacing any existing data  
there.

2-3. Channel Mode Message

Status 1101nnnn  
0ccccccc  
0vvvvvvv

(ii) 1 Performance Bulk Data

- C = 124 V=0 Omni Mode OFF/ALL NOTES OFF
- C = 125 V=0 Omni Mode OFF/ALL NOTES OFF
- C = 126 V=0 Mono Mode OFF/ALL NOTES OFF
- C = 127 V=0 Poly Mode OFF/ALL NOTES OFF

Status 11110000  
I.D. 01000011  
Sub-status/Ch. 0000nnnn  
Format Number 00000001  
Byte Count 00000000  
Byte Count 01011110  
Data Oddddddd  
⋮  
Oddddddd  
Check Sum 0eeeeeee  
EOX 11110111

Omni status (ON/OFF) is controlled on the  
front panel (in the Omni ON/OFF sub-mode)  
and has final priority. Changes in mode  
are accompanied by a compulsory voice dump  
and cleaning of the Key Assigner.

94 bytes of  
function data  
sent

2-4. System Real Time Message

Status 11111110 Active Sensing

This format is for the input of the  
function data of a single voice. The green  
Parameter Change LED flashes when data is  
received. Out of the 94 bytes sent, only  
the data corresponding to the TF1 goes  
into the Edit Buffer, altering the  
function data of any voice currently in  
the Edit Buffer.

When this code is received, sensing  
begins. If neither status nor data is  
received over an interval of 300 mS, the  
TF1 will stop sensing after first dumping  
all voices and clearing the Key Assigner.

(iii) 64 Performance Bulk Data

2-5. System Exclusive Message

2-5-1. Bulk Dump  
(ii) 1 Voice Bulk Data

Status 11110000  
I.D. 01000011  
Sub-status/Ch. 0000nnnn  
Format Number 00000000  
Byte Count 00000001  
Byte Count 00011011  
Data Oddddddd

Status 11110000  
I.D. 01000011  
Sub-status/Ch. 0000nnnn  
Format Number 00000010  
Byte Count 00100000  
Byte Count 00000000  
Data Oddddddd  
⋮  
4096 bytes of  
data sent

```

                Oddddddd
Check Sum      Oeeeeeee
EOX           11110111

```

This format is for loading function data into the TF1 Memory. It can only be input when the Memory Protect is OFF. When data is input, the Memory Protect LED will light for about 2 seconds. Only the first 32 of the 64 batches of data are function data, and they are loaded in order into the function memories of program destinations 1 thru 32.

#### iv) 32 Voice Bulk Data

```

Status         11110000
I.D.          01000011
Sub-status/Ch. 0000nnnn
Format Number  00001001
Byte Count    00100000
Byte Count    00000000
Data         Oddddddd
              ⋮
              4096 bytes of
              data sent
              ⋮
              Oddddddd
Check Sum     Oeeeeeee
EOX          11110111

```

This format is for loading voice data only into the TF1 memory. It can only be input when the Memory Protect is OFF. When data is input, the Memory Protect LED will light for about 2 seconds. The voice data for all 32 programs will be changed.

#### 2-5-2. Parameter Change

```

Status         11110000
I.D.          01000011
Sub-status/Ch. 0001nnnn
Parameter
Group Number   oggggghh    g = 0, 1, 2, 3
Parameter No.  Oppppppp    p = 0 - 127
EOX           11110111

```

The green Parameter Change LED will flash when data is received, and voice or function data in the Edit Buffer will be changed.

#### 2-5-3. Dump Request

```

Status         11110000
I.D.          01000011
Sub-status/Ch. 0010nnnn
Format Number  Offfffffff
              f = 0, 1, 2, 9, 125
EOX           11110111

```

The corresponding bulk data will be dumped through the MIDI OUT terminal.

### 3. OUTPUT DATA

Data is only output when a dump request signal is received from an external source or by direct panel switching. Since the only output is the COMMON MIDI OUT terminal, you must select the OUTPUT SLOT number corresponding to the number of the module from which you are outputting data. Data is always sent via MIDI channel 1 and consists of voice and function data in System Exclusive.

#### 3-1. Output Conditions

##### (a) Output for Dump Request

The following five kinds of data dump can be done, according to the selected format number ( ).

- f = 0 1 Voice Bulk Data  
Outputs voice data in the Edit Buffer
- f = 1 1 Performance Bulk Data  
Outputs function data in the Edit Buffer
- f = 2 64 Performance Bulk Data  
Outputs all function data from programs 1 thru 32 in order.
- f = 9 32 Voice Bulk data  
Outputs all voice data from programs 1 thru 32

(Formatting for the above is the same as for input).

f = 125

Condition Acknowledge

Status	11110000
I.D.	01000011
Sub-status/Ch.	00000000
Format Number	01111101
Byte Count	00000000
Byte Count	00010000
Data	0ddddddd
	⋮
	0ddddddd
Check Sum	0eeeeeee
EOX	11110111

**(b) Output in the Program Change sub-mode**

When you select a program using the front panel keys, the corresponding voice and function data will be output in the following order:

1. 1 Performance Bulk Data
2. 1 Voice Bulk Data

**(c) Output in the Dump sub-mode**

Data is output in the following order when you press the "YES" key (SW1):

1. 32 Voice Bulk Data
2. 64 Performance Bulk Data

## 4. SYSTEM EXCLUSIVE DATA FORMAT

## 4-1. DX7 Voice Parameter Change (g=0)

Sub-group Number h	Parameter Number p	Parameter	Data	Notes
0	0	OP6 EG RATE 1	0 ~ 99	
	1	OP6 EG RATE 2	0 ~ 99	
	2	OP6 EG RATE 3	0 ~ 99	
	3	OP6 EG RATE 4	0 ~ 99	
	4	OP6 EG LEVEL 1	0 ~ 99	
	5	OP6 EG LEVEL 2	0 ~ 99	
	6	OP6 EG LEVEL 3	0 ~ 99	
	7	OP6 EG LEVEL 4	0 ~ 99	
	8	OP6 KEYBOARD LEVEL SCALING BREAK POINT	0 ~ 99	* 1
	9	OP6 KEYBOARD LEVEL SCALING LEFT DEPTH	0 ~ 99	
	10	OP6 KEYBOARD LEVEL SCALING RIGHT DEPTH	0 ~ 99	
	11	OP6 KEYBOARD LEVEL SCALING LEFT CURVE	0 ~ 3	* 2
	12	OP6 KEYBOARD LEVEL SCALING RIGHT CURVE	0 ~ 3	* 2
	13	OP6 KEYBOARD RATE SCALING	0 ~ 7	
	14	OP6 AMPLITUDE MODULATION SENSITIVITY	0 ~ 3	
	15	OP6 KEY VELOCITY SENSITIVITY	0 ~ 7	
	16	OP6 OPERATOR OUTPUT LEVEL	0 ~ 99	
	17	OP6 OSCILLATOR MODE	0 ~ 1	* 3
	18	OP6 OSCILLATOR FREQUENCY COARSE	0 ~ 31	* 4
	19	OP6 OSCILLATOR FREQUENCY FINE	0 ~ 99	* 4
	20	OP6 OSCILLATOR DETUNE	0 ~ 14	* 5
	21 ~ 41	OP5		
	42 ~ 62	OP4		
	63 ~ 83	OP3		
	84 ~ 104	OP2		
	105 ~ 125	OP1		
1	126	PITCH EG RATE 1	0 ~ 99	
	127	PITCH EG RATE 2	0 ~ 99	
	0 (128)	PITCH EG RATE 3	0 ~ 99	
	1 (129)	PITCH EG RATE 4	0 ~ 99	
	2 (130)	PITCH EG LEVEL 1	0 ~ 99	
	3 (131)	PITCH EG LEVEL 2	0 ~ 99	
	4 (132)	PITCH EG LEVEL 3	0 ~ 99	
	5 (133)	PITCH EG LEVEL 4	0 ~ 99	
	6 (134)	ALGORITHM SELECT	0 ~ 31	
	7 (135)	FEEDBACK	0 ~ 7	
	8 (136)	OSCILLATOR KEY SYNC	0 ~ 1	
	9 (137)	LFO SPEED	0 ~ 99	
	10 (138)	LFO DELAY	0 ~ 99	
	11 (139)	LFO PITCH MODULATION DEPTH	0 ~ 99	
	12 (140)	LFO AMPLITUDE MODULATION DEPTH	0 ~ 99	
	13 (141)	LFO KEY SYNC	0 ~ 1	
	14 (142)	LFO WAVE	0 ~ 5	* 6
	15 (143)	LFO PITCH MODULATION SENSITIVITY	0 ~ 7	
	16 (144)	TRANSPOSE	0 ~ 48	Concert pitch at 24
	17 (145)	VOICE NAME 1	ASCII	
	18 (146)	VOICE NAME 2	ASCII	
	19 (147)	VOICE NAME 3	ASCII	
	20 (148)	VOICE NAME 4	ASCII	
	21 (149)	VOICE NAME 5	ASCII	
	22 (150)	VOICE NAME 6	ASCII	
	23 (151)	VOICE NAME 7	ASCII	
	24 (152)	VOICE NAME 8	ASCII	
	25 (153)	VOICE NAME 9	ASCII	
	26 (154)	VOICE NAME 10	ASCII	
1	27 (155)	OPERATOR ON/OFF	xxxxxxx	* 7
	28 (156)	OPERATOR SELECT	0 ~ 5	* 8



## \*1 BREAK POINT

BREAK POINT	0	1	2	3	4	5	15	27	39	51	63	75	87	99
MIDI NOTE #	21	22	23	24	25	26	36	48	60	72	84	96	108	120
NOTE	A <sub>1</sub>	A <sub>1</sub> #	B <sub>1</sub>	C <sub>0</sub>	C <sub>0</sub> #	D <sub>0</sub>	C <sub>1</sub>	C <sub>2</sub>	C <sub>3</sub>	C <sub>4</sub>	C <sub>5</sub>	C <sub>6</sub>	C <sub>7</sub>	C <sub>8</sub>

## \*2 KEYBOARD LEVEL SCALING CURVE

	0	1	2	3
CURVE	-LIN	-EXP	+EXP	+LIN

## \*3 OSCILLATOR MODE

\* 0 \*.....frequency ratio

\* 1 \*.....fixed frequency

## \*4 FREQUENCY COARSE/FINE

i) For Frequency Ratio

When FINE=0

COARSE	0	1	2	3	10	30	31
FREQUENCY RATIO	0.5	1	2	3	10	30	31

When Coarse=1

FINE	0	1	2	3	10	50	99
FREQUENCY RATIO	1.00	1.01	1.02	1.03	1.10	1.50	1.99

ii) For Fixed Frequency

When FINE=0

COARSE	0	1	2	3	4	5	6	7		31
FREQUENCY(Hz)	1	10	100	1000	1	10	100	1000		1000





When COARSE=0

FINE	0	1	2	3	4	5	10	20	50	99
FREQUENCY(Hz)	1.000	1.023	1.047	1.072	1.096	1.122	1.259	1.585	3.162	9.772

## \*5 DETUNE

	0	1	2	3	4	5	6	7	8	9	10	11	12	13	14
DETUNE	-7	-6	-5	-4	-3	-2	-1	0	1	2	3	4	5	6	7

## \*6 LFO WAVE

	0	1	2	3	4	5
WAVE	TRIANGLE 	SAW DOWN 	SAW UP 	SQUARE 	SINE 	SAMPLE/HOLD

## \*7 OPERATOR ON/OFF

Bit	b <sub>5</sub>	b <sub>4</sub>	b <sub>3</sub>	b <sub>2</sub>	b <sub>1</sub>	b <sub>0</sub>
OP	OP1	OP2	OP3	OP4	OP5	OP6

Bit Map

\* 0 \*...OFF \* 1 \*...ON

## \*8 OPERATOR SELECT

	0	1	2	3	4	5
OPERATOR	OP6	OP5	OP4	OP3	OP2	OP1

#### 4-2. DX Performance Parameter Change (g=1) (h=0)

Parameter Number p	Parameter	Data	Notes
0			
1	SOURCE SELECT	1 ~ 16	*3
2	POLY/MONO	0 ~ 1	
3	PITCH BEND RANGE	0 ~ 12	
4	PITCH BEND STEP	0 ~ 12	
5	PORTAMENTO TIME	0 ~ 99	
6	PORTAMENTO/GLISSANDO	0 ~ 1	
7	PORTAMENTO MODE	0 ~ 1	*1
8			
9	MODULATION WHEEL SENSITIVITY	0 ~ 15	
10	MODULATION WHEEL ASSIGN	0 ~ 7	*2
11	FOOT CONTROLLER SENSITIVITY	0 ~ 15	
12	FOOT CONTROLLER ASSIGN	0 ~ 7	*2
13	AFTER TOUCH SENSITIVITY	0 ~ 15	
14	AFTER TOUCH ASSIGN	0 ~ 7	*2
15	BREATH CONTROLLER SENSITIVITY	0 ~ 15	
16	BREATH CONTROLLER ASSIGN	0 ~ 7	*2
17			
18			
19			
20			
21			
22			
23			
24			
25			
26	AUDIO OUTPUT LEVEL ATTENUATOR	0 ~ 7	
27			
28			
29			
30			
31			
32			
33			
34			
63			
64	MASTER TUNING	0 ~ 127	Concert Pitch at 64

#### \*1 PORTAMENTO MODE

- \* 0 ...sustain-key pitch retain
- \* 1 ...sustain-key pitch follow

#### \*2 EFFECT ASSIGN

Bit	b <sub>2</sub>	b <sub>1</sub>	b <sub>0</sub>
ASSIGN	EG BIAS	AMPLITUDE	PITCH

#### \*3 SOURCE SELECT

Selects MIDI receive channel 1 to 16

#### 4-3. Function Parameter Change (g=2) (h=0)

Parameter Number p	Parameter	Data	Notes
64	POLY/MONO	0 ~ 1	
65	PITCH BEND RANGE	0 ~ 12	
66	PITCH BEND STEP	0 ~ 12	
67	PORTAMENTO MODE	0 ~ 1	
68	PORTAMENTO/GLISSANDO	0 ~ 1	
69	PORTAMENTO TIME	0 ~ 99	
70	MODULATION WHEEL SENSITIVITY	0 ~ 99	*1
71	MODULATION WHEEL ASSIGN	0 ~ 7	
72	FOOT CONTROLLER SENSITIVITY	0 ~ 99	*1
73	FOOT CONTROLLER ASSIGN	0 ~ 7	
74	BREATH CONTROLLER SENSITIVITY	0 ~ 99	*1
75	BREATH CONTROLLER ASSIGN	0 ~ 7	
76	AFTER TOUCH SENSITIVITY	0 ~ 99	*1
77	AFTER TOUCH ASSIGN	0 ~ 7	

#### \*1 EFFECT SENSITIVITY

Data received over a range of 0-99 is in the memory on a scale of 0-15

#### 4-4. DX9 Function Parameter Change (g=3) (h=0)

Parameter Number p	Parameter	Data	Notes
64			
65	MASTER TUNE	0 ~ 127	
66	POLY/MONO	0 ~ 1	
67	PITCH BEND RANGE	0 ~ 12	
68	PORTAMENTO MODE	0 ~ 1	
69	PORTAMENTO TIME	0 ~ 99	
70	MODULATION WHEEL SENSITIVITY	0 ~ 99	*1
71	MODULATION WHEEL ASSIGN : PITCH	0 ~ 1	
72	MODULATION WHEEL ASSIGN : AMPLITUDE	0 ~ 1	
73	MODULATION WHEEL ASSIGN : EG BIAS	0 ~ 1	
74	BREATH CONTROLLER SENSITIVITY	0 ~ 99	*1
75	BREATH CONTROLLER ASSIGN : PITCH	0 ~ 1	
76	BREATH CONTROLLER ASSIGN : AMPLITUDE	0 ~ 1	
77	BREATH CONTROLLER ASSIGN : EG BIAS	0 ~ 1	

#### 4-5. TX Function Parameter Change (g=4) (h=1)

Parameter Number p	Parameter	Data	Notes
0			
1			
2			
3			
4			
5	NOTE LIMIT LOW	0 ~ 127	
6	NOTE LIMIT HIGH	0 ~ 127	
7	TFI MEMORY PROTECT OFF/ON	0, 127	
8	TFI TEST PROGRAM ENTRY	127	FOR FACTORY TEST
9	TFI MIDI IN INDIVIDUAL	127	
10	TFI MIDI IN COMMON	127	

## 4-6. 1 Voice Bulk Data

155 bytes of data. The arrangement of this data is the same as in diagram 4-1, parameters 0 thru 154.

## 4-7. 1 Performance Bulk Data (f=1)

Address	Parameter	Data	Notes
0			
1			
2	VOICE A POLY/MONO	0 ~ 1	
3	VOICE A PITCH BEND RANGE	0 ~ 12	
4	VOICE A PITCH BEND STEP	0 ~ 12	
5	VOICE A PORTAMENTO TIME	0 ~ 99	
6	VOICE A PORTAMENTO/GLISSANDO	0 ~ 1	
7	VOICE A PORTAMENTO MODE	0 ~ 1	
8			
9	VOICE A MODULATION WHEEL SENSITIVITY	0 ~ 15	
10	VOICE A MODULATION WHEEL ASSIGN	0 ~ 7	
11	VOICE A FOOT CONTROLLER SENSITIVITY	0 ~ 15	
12	VOICE A FOOT CONTROLLER ASSIGN	0 ~ 7	
13	VOICE A AFTER TOUCH SENSITIVITY	0 ~ 15	
14	VOICE A AFTER TOUCH ASSIGN	0 ~ 7	
15	VOICE A BREATH CONTROLLER SENSITIVITY	0 ~ 15	
16	VOICE A BREATH CONTROLLER ASSIGN	0 ~ 7	
17			
18			
19			
20			
21			
22			
23			
24			
25			
26	VOICE A AUDIO OUTPUT LEVEL ATTENUATOR	0 ~ 7	
27			
28			
29			
30			
31	VOICE B		
32			
33			
34			
35			
36			
37			
38			
39			
40			
41			
42			
43			
44			
45			
46			
47			
48			
49			
50			
51			
52			
53			
54			
55			
56			
57			
58			
59			
60			
61	VOICE MEMORY SELECT FLAG	0 ~ 1	
62			
63			
64	PERFORMANCE NAME 1	ASCII	
65	PERFORMANCE NAME 2	ASCII	
66		ASCII	
67		ASCII	
68		ASCII	
69		ASCII	
70		ASCII	
71		ASCII	
72	PERFORMANCE NAME 29	ASCII	
73	PERFORMANCE NAME 30	ASCII	

#### 4-8. 64 Performance Bulk Data (f=2)

Data are listed in order for the 64 performances in units of 64 bytes (64 per performance). The TF1 uses the first 32 performances.

Address	6	5	4	3	2	1	0	Parameter	Data	Parameter	Data
0	F/M							VOICE A POLY/MONO	0 ~ 1		
1	PBS(LO)			PBR				VOICE A P. BEND STEP	0 ~ 12	PITCH BEND RANGE	0 ~ 12
2	PTIM							VOICE A PORTA. TIME	0 ~ 99		
3					M	GL		VOICE A PORTA. MODE	0 ~ 1	PORTAMENTO/GLISSANDO	0 ~ 1
4	MWA			MWS				VOICE A MOD. WHEEL ASN.	0 ~ 7	MOD. WHEEL SENS.	0 ~ 15
5	FCA			FCS				VOICE A FOOT CONT. ASN.	0 ~ 7	FOOT CONT. SENS.	0 ~ 15
6	ATA			ATS				VOICE A AFTER TOUCH ASN.	0 ~ 7	AFTER TOUCH SENS.	0 ~ 15
7	BCA			BCS				VOICE A BREATH CON ASN.	0 ~ 7	BREATH CON. SENS.	0 ~ 15
8											
9											
10											
11											
12											
13											
14					ATN			VOICE A ATTENUATION	0 ~ 7		
15	Pbs (H)							VOICE A PITCH B. STEP	(MSB)		
16	VOICE B										
31											
32					VMS	KMOD		VOICE MEMORY SELECT	0 ~ 1	KEY ASSIGN MODE	0 ~ 2
33											
34	PNAM 1							PERFORMANCE NAME 1	ASCII		
35											
63	PNAM 30							PERFORMANCE NAME30	ASCII		

With the Key Assign in Single mode(KMOD=0) Voice B are loaded with VMS.

## 4-9. 32 Voice Bulk Data (f=9)

Data are listed in order for the 32 programs in units of 128 bytes.

Address	6	5	4	3	2	1	0	Parameter	Data	Parameter	Data
0				R	1			OP6 EG RATE1	0 ~ 99		
1				R	2			OP6 EG RATE2	0 ~ 99		
2				R	3			OP6 EG RATE3	0 ~ 99		
3				R	4			OP6 EG RATE4	0 ~ 99		
4				L	1			OP6 EG LEVEL 1	0 ~ 99		
5				L	2			OP6 EG LEVEL 2	0 ~ 99		
6				L	3			OP6 EG LEVEL 3	0 ~ 99		
7				L	4			OP6 EG LEVEL 4	0 ~ 99		
8				B	P			SCALING BREAK P.	0 ~ 99		
9				L	D			SCALING LEFT DEPTH	0 ~ 99		
10				R	D			SCALING RIGHT DEPTH	0 ~ 99		
11						RC	LC	SCALING RIGHT CURVE	0 ~ 3	LEFT CURVE	0 ~ 3
12				PD			RS	OSCILLATOR DETUNE	0 ~ 14	RATE SCALING	0 ~ 7
13						KVS	AMS	KEY VELOCITY SENS.	0 ~ 7	AMPLITUDE MOD. SENS.	0 ~ 3
14				O	L			OUTPUT LEVEL	0 ~ 99		
15						F	C	FREQUENCY COARSE	0 ~ 31	OSCILLATOR MODE	0 ~ 1
16				F	F			FREQUENCY FINE	0 ~ 99		
17											
33				O	P	5					
34											
50				O	P	4					
51											
67				O	P	3					
68											
84				O	P	2					
85											
101				O	P	1					
102				P	R	1		PITCH EG RATE 1	0 ~ 99		
103				P	R	2		PITCH EG RATE 2	0 ~ 99		
104				P	R	3		PITCH EG RATE 3	0 ~ 99		
105				P	R	4		PITCH EG RATE 4	0 ~ 99		
106				P	L	1		PITCH EG LEVEL 1	0 ~ 99		
107				P	L	2		PITCH EG LEVEL 2	0 ~ 99		
108				P	L	3		PITCH EG LEVEL 3	0 ~ 99		
109				P	L	4		PITCH EG LEVEL 4	0 ~ 99		
110							ALS	ALGORITHM SELECT	0 ~ 31		
111						OKS	FB	OSCILLATOR KEY SYNC	0 ~ 1	FEEDBACK	0 ~ 7
112				L	F	S		LFO SPEED	0 ~ 99		
113				L	F	D		LFO DELAY	0 ~ 99		
114				L	P	M	D	LFO PITCH MOD DEPTH	0 ~ 99		
115				L	A	M	D	LFO AMP MOD DEPTH	0 ~ 99		
116				LPMS		LFW	LFS	LFO PITCH MOD SENS.	0 ~ 7	{ WAVE KEY SYNC	0 ~ 5 0 ~ 1
117				T	R	N	P	TRANSPOSE	0 ~ 48		
118				V	N	A	M	1	VOICE NAME 1	ASCII	
119				V	N	A	M	2	VOICE NAME 2	ASCII	
120				V	N	A	M	3	VOICE NAME 3	ASCII	
121				V	N	A	M	4	VOICE NAME 4	ASCII	
122				V	N	A	M	5	VOICE NAME 5	ASCII	
123				V	N	A	M	6	VOICE NAME 6	ASCII	
124				V	N	A	M	7	VOICE NAME 7	ASCII	
125				V	N	A	M	8	VOICE NAME 8	ASCII	
126				V	N	A	M	9	VOICE NAME 9	ASCII	
127				V	N	A	M	10	VOICE NAME 10	ASCII	

## 4-10. Condition Acknowledge (f = 125)

Address	Parameter	Data	Notes
0	CLASSIFICATION ASCII 'L'	\$4C	
1	CLASSIFICATION ASCII 'M'	\$4D	
2	CLASSIFICATION ASCII '□'	\$20	
3	CLASSIFICATION ASCII '□'	\$20	
4	MODEL NAME ASCII '8'	\$38	
5	MODEL NAME ASCII '9'	\$39	
6	MODEL NAME ASCII '5'	\$35	
7	MODEL NAME ASCII '0'	\$30	
8	MODEL NAME ASCII '□'	\$20	
9	MODEL NAME ASCII '□'	\$20	
10	SOFTWARE VERSION #	V	
11	SOFTWARE REVISION #	R	
12	CONDITION DATA 1 *1		
13	CONDITION DATA 2 RECEIVE CH	0 ~ 15	
14	CONDITION DATA 3 BATTERY VOLT		1 unit =
15	CONDITION DATA 4	0	0.1 volts

\*1: Bit Arrangement

bit	Parameter	Data	Notes
b0	PERFORMANCE ECHO BACK MODE	0	
b1	COMPUTER COMMUNICATION MODE	1	
b2	VOLUME CONTROL BY DATA ENTRY LEVER	0	
b3	CONTROL CHANGE RECEIVE	1	
b4	OMNI MODE	0 / 1	
b5	MEMORY PROTECT	0 / 1	
b6	DATA ENTRY RECEIVE	0 / 1	*2

\*2: "1" for Program Change sub-mode only; "0" at all other times.

Function ...	Transmitted	Recognized	Remarks
Basic Default	: x	: 1 - 16 *	: * memorized
Channel Changed	: x	: 1 - 16 *	:
Mode Default	: x	: 1,2,3,4 *	:
Mode Messages	: x	: POLY, MONO(M=1)	:
	:	: OMNIon, OMNIoff	: not altered
Note Number	: x	: 0 - 127	:
Velocity Note ON	: x	: 0	:
Velocity Note OFF	: x	: x	:
After Key's	: x	: x	:
Touch Ch's	: x	: 0	:
Pitch Bender	: x	: 0	:
Control Change	1 : x 2 : x 4 : x 5 : x 6 : x 7 : x	: 0 : 0 : 0 : 0 : 0 : 0	: Modulation wheel : Breath control : Foot controller : Portamento time : Data entry knob : Volume
	64 : x 65 : x	: 0 : 0	: Sustain foot sw : Portamento f sw
	96 : x 97 : x	: 0 : 0	: Data entry +1 : Data entry -1
Prog Change	: x : True #	: 0 0 - 127 : 0 - 31	:
System Exclusive	: 0	: 0	: Voice parameters
System Common	: Song Pos : x : Song Sel : x : Tune : x	: x : x : x	:
System Real Time	: Clock : x : Commands : x	: x : x	:
Aux Messages	: Local ON/OFF : x : All Notes OFF : x : Active Sense : x : Reset : x	: x : x : 0 : x	:
Notes	:	:	:



# ■ BLOCK DIAGRAM

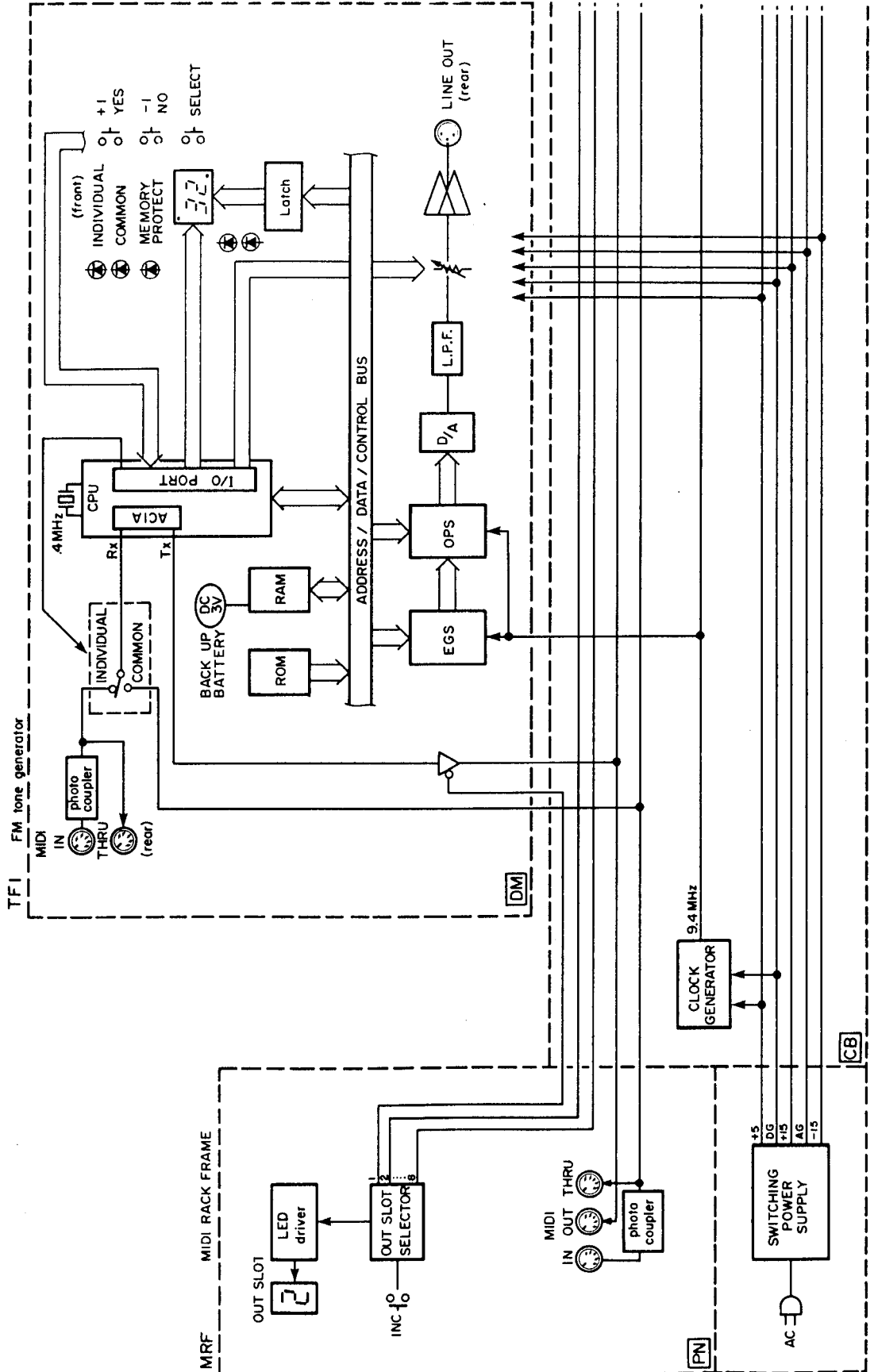

TF4

## CIRCUIT BOARDS & ELECTRICAL PARTS

Ref. No.	Part No.	Description	部 品 名	Remarks	Common Model	Markets	ランク
*	NA 81 38 10	DM Circuit Board	#92190	D M シ ー ト			460
	FZ 00 41 10	Semiconductive Ceramic Cap.	0.1 $\mu$ F 16V	半 導 体 セ ラ コ ン			010
	FI 36 42 20	Electro Magnetic Interference	0.022 $\mu$ F 50V	エ ミ ヲ イ ル			020
	FP 33 71 00	Tantalum Capacitor	10 $\mu$ F 16V	タ ン タ ル コ ン			020
*	GE 30 06 10	Ferrite Bead	BL02RN1	フ ェ ラ イ ト ビ ー ズ			010
	UK 44 64 70	Bipolar Electrolytic Cap.	4.7 $\mu$ F 25V	B P ケ ミ コ ン			010
	UK 13 81 00	"	100 $\mu$ F 16V	"			020
	FT 55 21 20	Polypropylene Cap.	120pF 50V	ポ リ プ ロ コ ン			030
	FT 55 24 70	"	470pF 50V	"			031
	HU 07 55 60	Metal Film Resistor	560 $\Omega$ 1/4W	金 属 皮 膜 抵 抗			021
	HU 07 61 00	"	1k $\Omega$ 1/4W	"			021
	HU 07 62 00	"	2k $\Omega$ 1/4W	"			021
	HZ 00 31 90	Module Resistor	4.7k $\Omega$ ×8	モ ジ ュ ー ル 抵 抗			010
	Hi 20 99 90	Trimmer Potentiometer	10M $\Omega$	ソ リ ッ ド V R			010
	HT 37 00 80	"	B20k $\Omega$	"			021
	iA 10 15 70	Transistor	2SA1015(O,Y)	ト ラ ン ジ ス タ			031
	iC 18 15 80	"	2SC1815(Y,GR)	"			031
	iC 21 20 00	"	2SC2120(O,Y)	"			031
	iF 00 34 50	Diode	1SS133	ダ イ オ ー ド			010
	iF 00 56 40	"	0A95	"			010
*	iF 00 84 10	LED	SLC-22VR3	L E D	RED		020
*	iF 00 84 20	"	SLC-22DU3	"	YELLOW		020
*	iF 00 84 30	"	SLC-22MG3	"	GREEN		020
*	iF 00 74 10	LED Digital Display	LA-301VB	7セグメントLED			050
	iG 00 16 90	IC	TC4016BP	I C			050
	iG 00 12 70	"	TC4066BP	"			051
	iG 09 64 00	"	TC40H008P	"	Quad 2 Input AND		030
	iG 05 11 00	"	TC40H074P	"	Dual D Type Flip Flop		040
	iG 02 70 10	"	HD74LSO4P	"	Hex Inverter		041
	iG 10 64 00	"	M74LS32P	"	Quad 2 Input OR		030
	iG 04 42 00	"	HD74LS138P	"	3 to 8 Line Deceder		041
	iG 07 86 00	"	TC40H374P	"	Octal D Type Flip Flop		070
	iG 05 26 00	"	HD74LS05P	"	Hex Inverter with DC		031
*	iG 14 06 00	"	HD6303X	"	8 Bit MPU		140
	iG 04 38 00	"	HD7417P	"	Hex Buffer 15V OC		030
	iG 13 49 00	"	IR9311	"	Comparator		040
	iG 00 13 90	"	NJM4558DV	"	OP Amp		030
	iG 10 62 00	"	M5M5118P-15	"	16k S-RAM		120
	iG 10 60 00	"	BA9221	"	12 Bit DAC		100
	iG 07 95 00	"	iG079500	"	Clock Buffer	X	050
*	iG 10 71 00	"	LF356N	"	OP Amp		050
*	iN 01 04 20	"	HN4827128G-30	"	ROM		190
	iG 08 19 00	"	HA17408P	"	D-A Converter		070
	iG 11 62 00	"	PST518B	"	System Reset	X	040
	iG 10 70 00	"	NJM072D	"	Dual OP Amp		040
	iG 04 25 00	"	NJM4556DV	"	OP Amp		040
	iR 00 14 00	"	TC74HC14P	"	Hex Inverter Schmitt	Trigger	050
	iT 21 28 00	"	YM2128	"	OPS		200
	iT 21 29 00	"	YM2129	"	EGS		170
	iK 00 02 60	Photo Conductor	P873-G35-201B	フ ォ ト カ プ ラ ー			070
	iK 00 04 70	"	TLP552	"			060
	QU 00 48 00	Ceramic Oscillator	4MHz	セ ラ ロ ッ ク			030
	PC 90 00 40	Lithium Battery	CR2032T	リ チ ウ ム 電 池			042

\*New Parts (新規部品)

ランク: Japan only

Ref. No.	Part No.	Description	部 品 名	Remarks	Common Model	Markets	ランク
	KA 90:69:30	Momentary Key Switch		キ ー ス イ ッ チ			010
	KC 00:13:00	Relay	RZ-12	リ レ ー			070
	LB 50:05:20	DIN Jack	5P	D I N ジャ ッ ク	MIDI		031
*	LB 30:23:40	Cannon Connector	XLB-3-32	キャノンソケット	LINE OUT		060
	LB 60:73:30	IC Socket	28P	I C ソ ケ ッ ト			050
	LB 00:90:40	Connector Housing	4P	コネクタハウジング	XH		010
	LB 10:11:30	Contact Pin		コ ン タ ク ト ピ ン	"		010
	GE 30:07:10	Line Filter		フェライトリング			070
	LB 91:80:40	Connector Base Pin	4P	コネクタベースピン	XH		010
*	LB 02:12:20	Connector	22P	カードフィットコネクタ	ZIF V-type		040
*	LB 60:73:60	"	22P	"	" H-type		040
	<b>NA 81:38:20</b>	<b>CB Circuit Board</b>	#92200	C B シ ー ト			180
	FZ 00:41:10	Semiconductive Ceramic Cap.	0.1 $\mu$ F 16V	半 導 体 セ ラ コ ン			010
	iG 05:10:00	IC	TC40H004P	I C	Hex Inverter		030
*	QU 00:52:00	Quarz Crystal Unit	9.4265MHz	水 晶 振 動 子			050
	LB 60:31:30	Connector Base Pin	12P	コネクタベースピン	NH		031
	LB 60:81:20	Connector	8P	モレックスコネクタ			030
*	LB 60:76:00	"	20P	カードエッジコネクタ			050
	Ei 33:01:06	Bind Head Tapping Screw	3 $\times$ 10	バインドタッピングネジ			010
*	<b>NA 81:38:30</b>	<b>PN Circuit Board</b>	#92210	P N シ ー ト			160
	FZ 00:41:10	Semiconductive Ceramic Cap.	0.1 $\mu$ F 16V	半 導 体 セ ラ コ ン			010
	GE 30:06:00	Ferrite Bead		フェライトビーズ			010
	iF 00:00:40	Diode	1S1555	ダ イ オ ード			010
	iF 00:74:10	LED Digital Display	LA-301VB	7セグメントLED			050
	iR 00:14:00	IC	TC74HC14	I C	Hex Inverter Schmitt Trigger		050
	iG 05:26:00	"	HD74LS05P	"	Hex Inverter with DC		031
	iG 04:42:00	"	HD74LS138P	"	3 to 8 Line Decoder		041
*	iG 14:41:00	"	HD74LS247	"	BCD to 7-segment Decoder		040
	iG 11:54:00	"	HD74LS283P	"	4 Bit Full Adder		040
	iG 05:03:00	"	HD74LS293P	"	4 Bit Binary Counter		040
	iK 00:04:70	Photo Conductor	TLP552	フ ォ ト カ プ ラ ー			060
*	KA 90:69:90	Momentary Key Switch		キ ー ス イ ッ チ			010
*	LB 50:03:80	DIN Jack	5P	D I N ジャ ッ ク	MIDI		020
	LB 50:03:70	Connector Base Pin	5P	コネクタベースピン	NH		020
	LB 60:30:10	"	8P	"	"		030
*	Mi 80:33:50	CP Wire	8P	C P ジャ ン バ ー			020
*	CB 83:50:50	Spacer, Isolator		絶 縁 ス ペ ー サ ー			020
*	CB 83:50:60	Ground Sheet		ア ー ス シ ー ト			030
*	<b>NA 81:38:40</b>	<b>AC Circuit Board</b>	#92220	A C シ ー ト		J	140
*	<b>NA 81:38:50</b>	<b>"</b>	#92220	<b>"</b>		U,C	
*	<b>NA 81:38:60</b>	<b>"</b>	#92220	<b>"</b>		G,WG	
	FZ 00:28:50	Ceramic Cap.	0.0022 $\mu$ F AC125V	セ ラ コ ン		J,U,C	020
	Fi 38:32:20	"	0.0022 $\mu$ F AC125V	"		G,WG	
	Fi 38:34:70	"	4700pF	"		G,WG	
	FR 16:42:20	Multiple Components	0.022 $\mu$ F 250V	ス パ ー ク キ ラ ー コ ン			040
	FZ 00:51:10	Metalized Plastic Cap.	0.047 $\mu$ F	メタライズドプラスチックコン		J,U,C	030
	FT 42:44:70	Metalized Polyester Cap.	0.047 $\mu$ F	メタライズドポリエステルコン		G,WG	
	GE 90:13:70	Coil	SC-05-100	コ イ ル			050
	GE 90:13:80	"	GP-5 Core	"			070
*	KA 80:48:20	Power Switch	SDGA3P	パ ワ ー ス イ ッ チ			050

\*New Parts (新規部品)

ランク: Japan only

Ref. No.	Part No.	Description	部 品 名	Remarks	Common Model	Markets	ランク
	KB 00 03 80	Fuse	4A 250V	ヒ ュ ー ズ		J	010
	KB 00 26 40	"	4A 250V	"		U,C	
	KB 00 26 20	"	T1.6A 250V	"		G,WG	
	LA 00 36 90	Ground Lug	B4S	歯 付 ア ー ス ラ グ			010
	LB 20 15 30	Fuse Holder Pin		ヒ ュ ー ズ ホ ル ダ ー ピ ン			010
	LA 00 44 00	Terminal		エ ー ス 用 フ ァ ス ト ン			010
	LB 30 14 70	Cap,3P	LB-03TV	3 P キ ャ ッ プ			020
	NP 80 90 00	Power Supply Unit		電 源 ユ ニ ッ ト		J,U,C	460
	NP 81 00 00	"		"		G,WG	
T1	XX 80 29 10	Inverter Transformer	3900111E	イ ン バ ー タ ト ラ ン ス			16*
	XX 80 29 20	Choke Coil	SC-02-300	チ ョ ー ク コ イ ル			06*
	XX 80 29 30	"	SKP-2-50	"			05*
L3	XX 80 28 60	"	831035E	"			070
D1	iX 80 06 10	Bridge Rectifier	S4VB40	ブ リ ッ ジ ダイ オ ー ド			050
D2	iX 55 00 50	Diode	1S953	ダイ オ ー ド			010
D3	iX 00 02 50	"	F114B	"			030
D6,7	iX 00 02 70	"	F114F	"			040
D8,9,11	iX 80 06 20	"	U19B	"			030
D12	iX 80 06 30	"	ESAC82-004	"			050
D13	iX 80 06 40	"	ESAD83-004	"			080
D14,15	iX 55 02 60	"	SM-1A-02	"			010
D4,5	iF 00 17 00	Zener Diode	RD15EB2	ツ ェ ナ ー ダイ オ ー ド			010
D19	iF 00 34 40	"	RD6.2EB	"			010
D20	iF 00 16 70	"	RD6.8EB2	"			010
D21	iX 80 06 50	"	RD2.7EB	"			01*
Q1	iX 80 06 70	Transistor	2SA1152	ト ラ ン ジ ス タ			030
Q2	iX 80 06 80	"	2SC2721	"			030
Q7	iX 55 04 10	"	2SC2719	"			031
Q3,9	iX 80 06 90	FET	2SK319	F E T			080
IC1	iX 80 07 00	IC	YD-020	I C			090
IC2	iG 06 39 00	"	μPC7815H	"			050
IC3	iG 07 75 00	"	μPC7915H	"			050
PC1,2	iX 80 07 10	Photo Conductor	PC-511	フ ォ ト カ プ ラ ー			050
CR1	iX 80 07 20	Triac	AC08DGM	ト ラ イ ア ッ ク			070
CR2	iX 80 07 30	SCR	8P2M	サ イ リ ス タ			070
RV1	HX 80 02 10	Trimmer Potentiometer	PN822H301V	ソ リ ッ ド V R	300Ω		02*
C3	FR 15 52 20	Metalized Paper Cap.	0.22μF 250V	M P コ ン			050
C4,37	FT 17 51 00	Polypropylene Cap.	0.1μF 100V	ポ リ プ ロ コ ン			032
C11,12	FT 17 31 00	"	1000pF 100V	"			030
R1	HX 80 02 30	Metal Film Resistor	680kΩ 1/2W	金 属 皮 膜 抵 抗			02*
R4,46 48	HU 07 61 00	"	1kΩ 1/4W	"			021
R5	HU 57 72 20	"	22kΩ 1/2W	"			021
R6	HU 07 65 60	"	5.6kΩ 1/4W	"			021
R7	HU 07 71 00	"	10kΩ 1/4W	"			021
R8	HU 07 68 20	"	8.2kΩ 1/4W	"			021
R14~17 24,45	HU 07 41 00	"	10 Ω 1/4W	"			021
R21	HU 07 72 70	"	27kΩ 1/4W	"			021
R22	HU 07 64 70	"	4.7kΩ 1/4W	"			021
R23,24	HU 07 74 70	"	47kΩ 1/4W	"			021
R25,27	HX 80 02 60	"	56Ω 1/2W	"			02*
R31	HU 57 62 20	"	22Ω 1/2W	"			021
R32~34	HU 07 62 20	"	2.2kΩ 1/4W	"			021

\*New Parts (新規部品)

ランク : Japan only



# EXPLODED VIEW

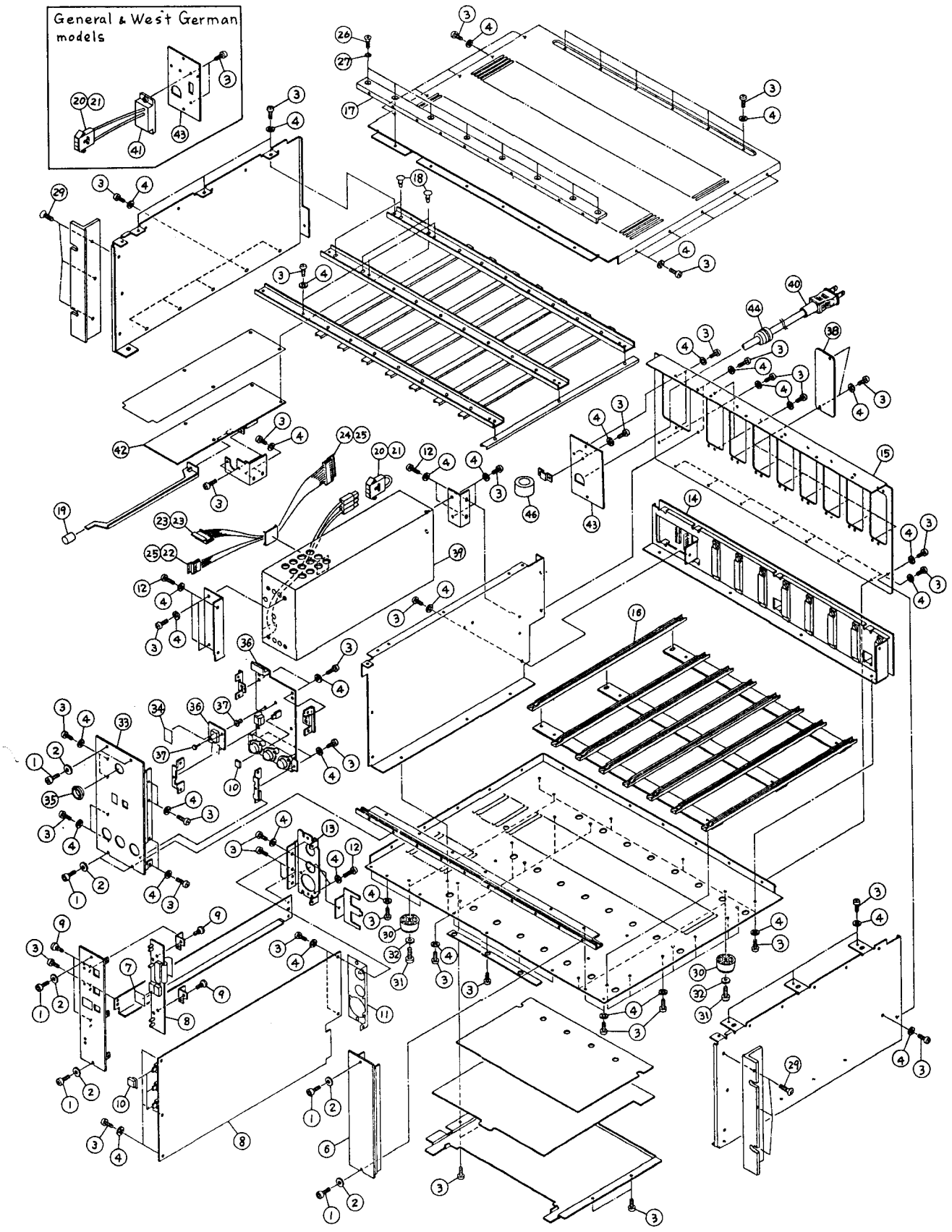

Ref. No.	Part No.	Description	部 品 名			Remarks	Common Model	Markets	ランク
1	EX 80 04 90	Bolt with Hexagonal Head	M3×6	BI	六角穴付ボルト				01*
2	EV 20 30 36	Flat Washer	3S	BI	平 座 金				010
3	ED 33 00 66	Bind Head Screw	M3×6	BI	バインド小ネジ				010
4	EV 41 30 36	Toothed Lock Washer	A3S	BI	歯付座金				010
* 5	BA 80 99 20	TF1 Panel			T F 1 パネル				080
* 6	BA 81 02 00	Blank Panel A			ブランクパネル A	TX116/216			080
* 7	CB 83 49 80	Filter, LED			L E D フィルター				040
* 8	NA 81 38 10	DM Circuit Board	#92190		D M シ ー ト				460
9	CB 06 88 80	Plastic Rivet			プラスチックリベット				010
* 10	CB 83 64 70	Push Button			プッシュボタン				010
* 11	CB 83 50 20	Earth Sheet			アースシート				020
12	ED 33 01 06	Bind Head Screw	3×10	BI	バインド小ネジ				010
13	AA 83 22 20	TF1 Rear Panel			T F 1 リアパネル				060
* 14	NA 81 38 20	CB Circuit Board	#92200		C B シ ー ト				180
* 15	AA 83 23 20	Back Panel			バックパネル				100
16	CB 83 50 00	Rail, Guide			ガイドレール				030
* 17	BA 80 99 60	Panel Rail			パネルレール				080
18	CB 83 29 30	Spacer, Locking Card			ロッキングカードスペーサー				010
19	CB 06 65 10	Push Button			プッシュボタン				010
20	LB 30 11 50	Connector Housing	3P	Red	コネクタハウジング				010
21	LB 10 06 80	Contact Pin			コンタクトピン				010
22	LB 50 02 40	Connector Housing	5P		コネクタハウジング	NH			010
23	LB 60 24 80	"	8P		"	"			010
24	LB 60 29 20	"	12P		"	"			010
25	BB 00 44 30	Contact Pin			コンタクトピン				010
26	EB 33 00 66	Flat Head Screw	3×6	BI	皿 小 ネ ジ				010
* 27	EV 44 00 30		3S	BI	皿 歯付座金				01*
* 28	AA 83 23 40	Top Cover			トップカバー				130
29	EB 34 00 86	Flat Head Screw	4×8	BI	皿 小 ネ ジ				010
30	CB 07 28 70	Leg			脚				010
31	ED 34 01 06	Bind Head Screw	4×10	BI	バインド小ネジ				010
* 32	EV 41 30 46	Toothed Lock Washer	A4S	BI	歯付座金				010
* 33	BA 80 99 30	MRF Panel			M R F パネル				090
* 34	CB 83 49 90	Filter, LED			L E D フィルター				040
35	CB 81 92 00	Switch Escutcheon			スイッチエスカッション				020
* 36	NA 81 38 30	PN Circuit Board	#92210		P N シ ー ト				160
* 37	CB 83 50 70	PB Rivet			P B リベット				010
* 38	AA 83 34 80	Blank Panel B			ブランクパネル B	TX116/216			030
* 39	NP 80 90 00	Power Supply Unit			電源ユニット			J, U, C	460
* "	NP 81 00 00	"			"			G, WG	
40	MG 00 06 10	Power Supply Cord			電源コード			J	060
"	MG 00 01 00	"			"			U	
"	MG 00 02 70	"			"			C	
"	MG 00 11 10	"			"			G	
"	MG 00 04 50	"			"			WG	
41	KA 40 08 30	Voltage Selector			電圧切替器			G, WG	
* 42	NA 81 38 40	AC Circuit Board	#92220		A C シ ー ト			J	140
* "	NA 81 38 50	"	#92220		"			U, C	
* "	NA 81 38 60	"	#92220		"			G, WG	
* 43	AA 83 23 50	AC Panel			A C パネル			J, C	050
"	AA 83 23 60	"			"			U	
"	AA 83 23 70	"			"			G, WG	
44	CB 80 68 50	Cord Stopper	6N3-4		コードストッパー			J, C	021

\*New Parts (新規部品)

ランク: Japan only

